

6

5

4

3

2

1

TYPE	OUTPUT		POLE	TIME RATING	VOLTAGE V	Hz	SYN. SPEED R.P.M
	HP.	kW.					
AEHCNH	450	335.5	4	CONT	2300/4000	60	1800

TOTALLY ENCLOSED FAN-COOLED VERTICAL HOLLOW SHAFT TYPE, SQUIRREL CAGE ROTOR

NOTE:

1. DIMENSIONS IN INCH
2. FRAME NO.5808
3. F CLASS INSULATION, S.F.: 1.15
4. FOR DIRECT COUPLING.
5. BEARING SIZE:
UPPER BEARING: 7328B [INSULATED]
LOWER BEARING: 6320C3 [UNINSULATED]
6. UPPER BEARING IS INSULATED. ANY METAL CONNECTIONS TO IT MUST BE INSULATED.
7. LUBRICATION:
UPPER BEARING USE OIL.
OIL VISCOSITY: ISO VG68 [300SSU AT 100 °F]
OIL QUANTITY: 3.4 GAL
LOWER BEARING USE GREASE. [MOBIL POLYREX EM]
8. ROTATION: COUNTER-CLOCKWISE [VIEW FROM TOP].
9. WITH NON-REVERSE RATCHET MECHANISM.
10. WITH GIB KEY: 0.625X0.625X3.07, 1PCS
11. APPROXIMATE WEIGHT: 6020
12. DOWNTHRUST: 9,700 LBS (L10-8800HRS)
13. REED FREQUENCY: 44 HZ
14. SPACE HEATER RATED AT 120 VOLT, SINGLE PHASE, 218 WATTS, LEADS TERMINATE IN MAIN LEAD BOX.

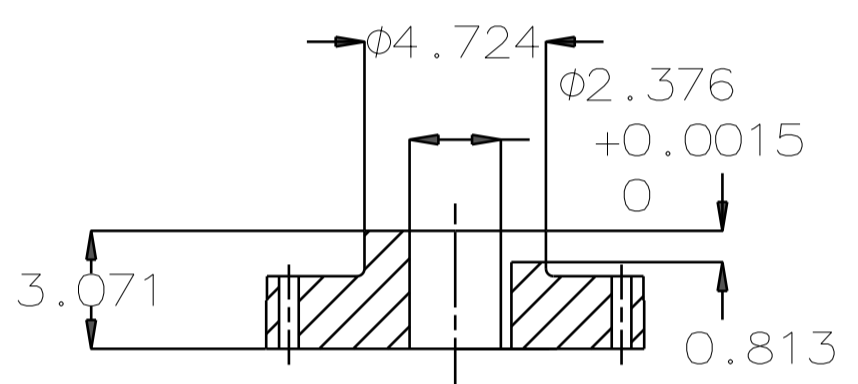
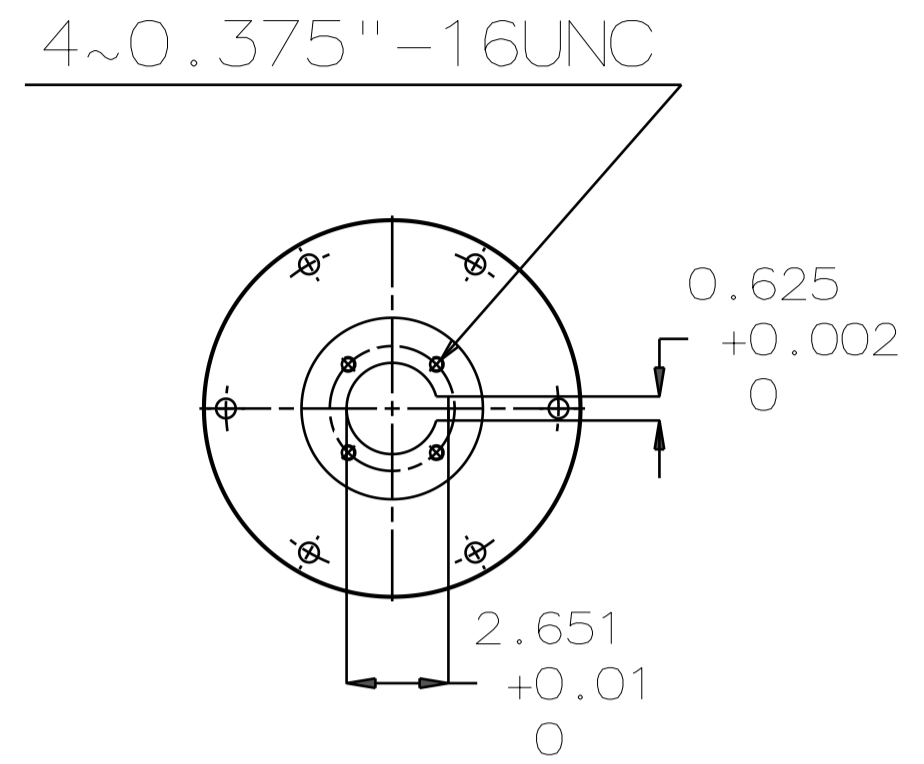
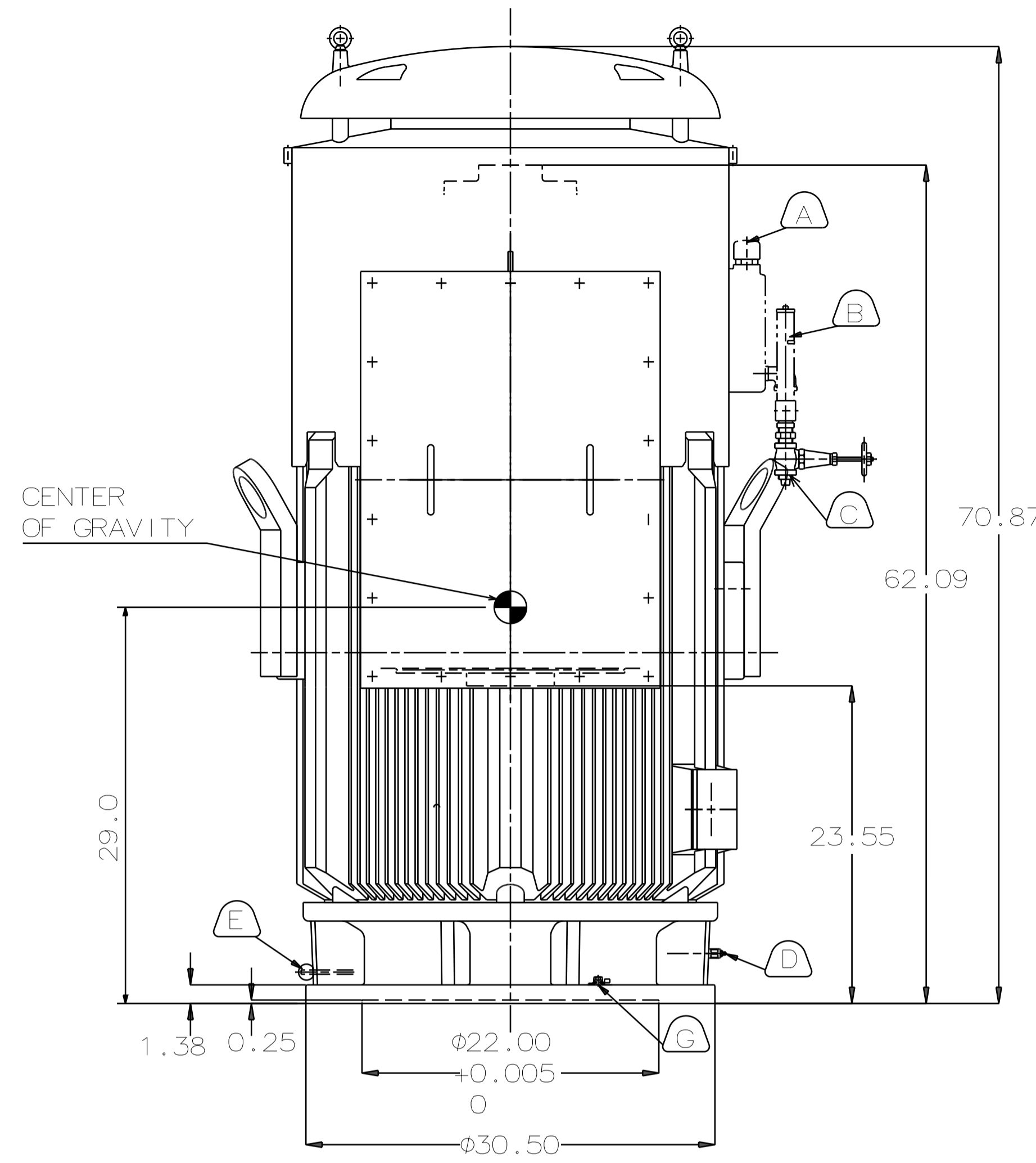

COUPLING [ENLARGED VIEW]

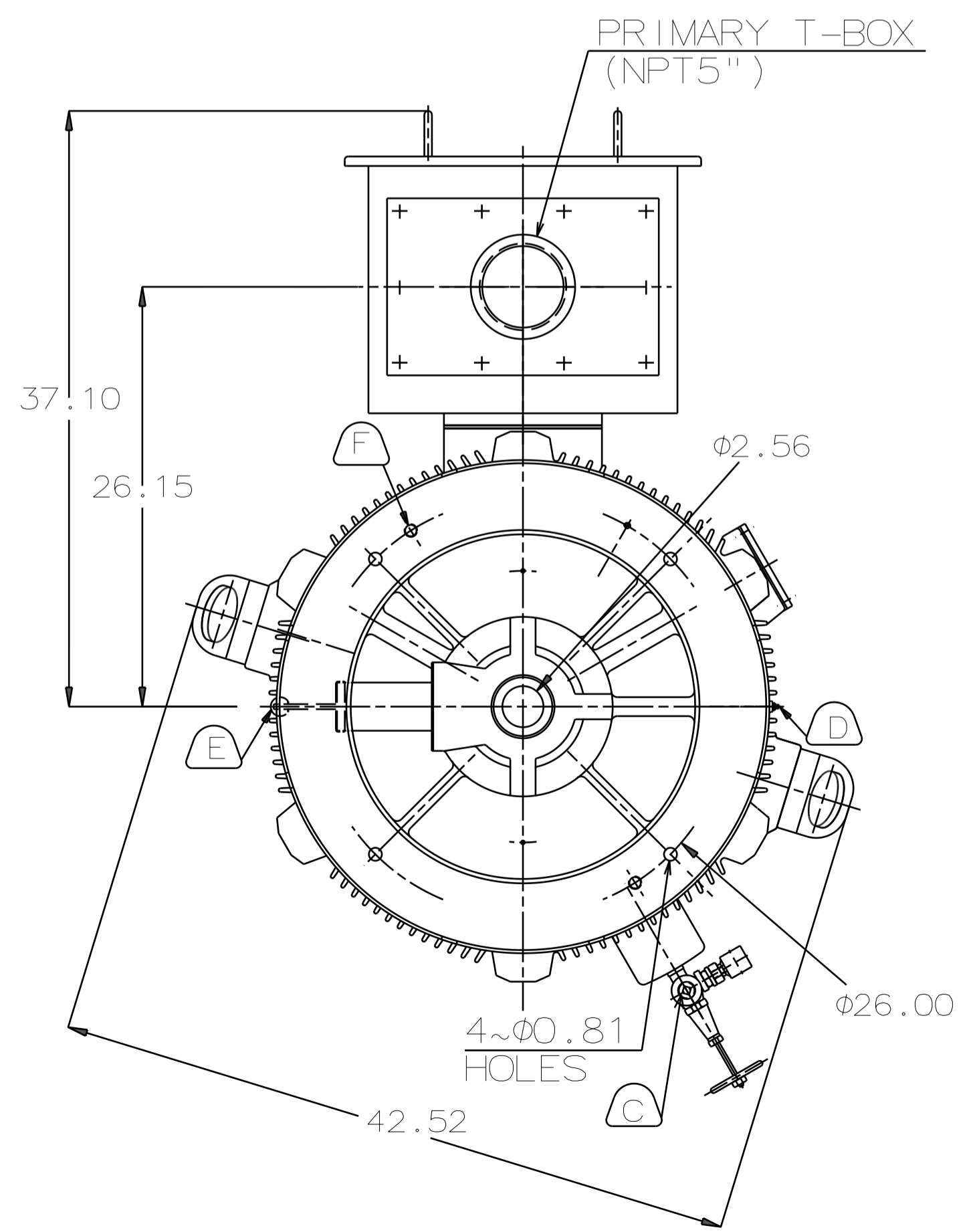

- (A) OIL FILLER [UPPER BEARING]
- (B) OIL GAUGE [UPPER BEARING]
- (C) OIL DRAIN [UPPER BEARING]
- (D) GREASE INLET [LOWER BEARING]
- (E) GREASE DISCHARGER [LOWER BEARING]
- (F) 2~M20 VERTICAL JACKING HOLES, 180° APART IN MOTOR BASE.
- (G) M10 TAPPED HOLE IN MOTOR BASE WITH GROUNDING TERMINAL [R38-10] & BOLT LOCATED AS SHOWN.

DATE	DEC 08 2016	OUTLINE DIMENSIONS	
	VHKTP4504	3-PHASE INDUCTION MOTOR	
DWG NO.	4B040L412	REV:00	

DWN.	Y. YANG	MAY. 25. 2015
CHKD.	R. LEE	MAY. 25. 2015
APPD.	C. L IU	MAY. 25. 2015



6

5

4

3

2

1